

330B / 430B LOG LOADER

S/N – WM330BX004312

S/N – WM430BX004317

S/N WC330B011005 –

S/N WC430B012009 – WC430BX012092

TECHNICAL MANUAL 330B / 430B LOG LOADER TMF307843

CALIFORNIA Proposition 65 Warning

Diesel engine exhaust and some of its constituents are known to the State of California to cause cancer, birth defects and other reproductive harm.



WARNING

The engine exhaust from this product contains chemicals known to the State of California to cause cancer, birth defects or other reproductive harm.

Worldwide Construction and Forestry Division

English

Table of Contents

Section

- 1 Introduction
- 2 Safety Rules
- 3 Theory of Operation
- 4 Specifications
- 5 Test Procedures and Adjustments
- 6 Hydraulic System
- 7 Electrical System
- 8 Troubleshooting
- 9 Maintenance and Repair
- 10 Cab

Appendix

- A Model S240 and Models S260/S261 Slashers
- B Model D250 Delimber

**Thanks very much for your reading,
Want to get more information,
Please click here, Then get the complete
manual**

JustClickHere 

NOTE:

**If there is no response to click on the link above,
please download the PDF document first, and then
click on it.**

**Have any questions please write to me:
admin@servicemanualperfect.com**

This Page Intentionally Left Blank

1. Introduction

READ THIS MANUAL carefully to learn how to operate and service your machine correctly. Failure to do so could result in personal injury or equipment damage. This manual and safety signs on your machine may also be available in other languages. (See your John Deere dealer to order.)

THIS MANUAL SHOULD BE CONSIDERED a permanent part of your machine and should remain with the machine when you sell it.

MEASUREMENTS in this manual are given in both metric and customary U.S. unit equivalents. Use only correct replacement parts and fasteners. Metric and inch fasteners may require a specific metric or inch wrench.

RIGHT-HAND AND LEFT-HAND sides are determined by facing in the direction of forward travel.

WRITE PRODUCT IDENTIFICATION NUMBERS (P.I.N.) in the Machine Numbers section. Accurately record all the numbers to help in tracing the machine should it be stolen. Your dealer also needs these numbers when you

order parts. File the identification numbers in a secure place off the machine.

WARRANTY is provided as part of John Deere's support program for customers who operate and maintain their equipment as described in this manual. The warranty is explained on the warranty certificate which you should have received from your dealer.

This warranty provides you the assurance that John Deere will back its products where defects appear within the warranty period. In some circumstances, John Deere also provides field improvements, often without charge to the customer, even if the product is out of warranty. Should the equipment be abused, or modified to change its performance beyond the original factory specifications, the warranty will become void and field improvements may be denied. Setting fuel delivery above specifications or otherwise overpowering machines will result in such action.

THE TIRE MANUFACTURER'S warranty supplied with your machine may not apply outside the U.S.

CALIFORNIA PROPOSITION 65 WARNING

Diesel engine exhaust and some of its constituents are known to the State of California to cause cancer, birth defects and other reproductive harm.

EMISSIONS CONTROL WARRANTY STATEMENT FOR NEW TIMBERJACK FORESTRY EQUIPMENT (U.S. AND CANADA)

To determine if the engine in your machine qualifies for the additional warranties set forth below, look for the "Engine Information" label located on your engine. If you reside in the United States and the engine label states: "Engine conforms to US EPA regulations on heavy duty non road diesel cycle engines," you are entitled to the "U.S. Emission Control Warranty Statement." If you reside in California, and the engine label states: "Engine conforms to California regulations on heavy duty non road diesel cycle engines," you are entitled to the "California Emission Control Warranty Statement."

U.S. EPA EMISSIONS CONTROL WARRANTY STATEMENT

Emissions control-related parts and components are warranted by Timberjack for five years or 3000 hours of operation, whichever occurs first. Timberjack further warrants that the engine covered by this warranty was designed, built, and equipped so as to conform at the time of sale with all U.S. emissions standards at the time of manufacture, and that it is free of defects in materials and workmanship which would cause it not to meet these standards within the period of five years or 3000 hours of operations, whichever occurs first.

Warranties stated on this certificate refer only to emissions-related parts and components of your engine. The complete machine warranty, less emissions-related parts and components, is provided separately as "Timberjack "Secure Warranty" For New Forestry Machine Products."

CALIFORNIA EMISSION CONTROL WARRANTY STATEMENT YOUR WARRANTY RIGHTS AND OBLIGATIONS

The California Air Resources Board (CARB) and Timberjack are pleased to explain the emission control system on your new engine. In California, new heavy-duty engines must be designed, built and equipped to meet the State's stringent anti-smog standards. Timberjack must warrant the emission control system on your engine for the periods of time listed below provided there has been no abuse, neglect, or improper maintenance of your machine.

Your emissions control system includes:

- Fuel Metering System
 - Fuel Injection System
- Air Induction System
 - Intake Manifold
 - Turbocharger System
 - Charge Air Cooling System
- Miscellaneous Items used in Above Systems

Where a warrantable condition exists, i.e. failure due to defect in Timberjack-supplied material and/or workmanship, Timberjack will repair your heavy-duty engine at no cost to you including diagnosis, parts and labor

TIMBERJACK'S WARRANTY COVERAGE:

The emission control system of your heavy-duty engine is warranted for five years or 3000 hours of operation, whichever occurs first. If any emission-related part on your engine is defective, the part will be repaired or replaced by Timberjack. Warranties stated on this certificate refer only to emissions-related parts and components of your engine. The complete machine warranty, less emissions-related parts and components, is provided separately as the "Timberjack "Secure Warranty" For New Forestry Machine Products."

OWNER'S WARRANTY RESPONSIBILITIES:

As the heavy-duty engine owner, you are responsible for the performance of the required maintenance as outlined in the

Operator's Manual. Timberjack recommends that you retain all receipts covering maintenance on your heavy-duty engine, but Timberjack cannot deny warranty solely for the lack of receipts or for your failure to ensure the performance of all scheduled maintenance.

However, as the heavy-duty engine owner, you should be aware that Timberjack may deny you warranty coverage if your heavy-duty engine or a part has failed due to abuse, neglect, improper maintenance or unapproved modifications.

Your engine is designed to operate on diesel fuel only. Use of any other fuel may result in your engine no longer operating in compliance with California's emissions requirements.

You are responsible for initiating the warranty process. The CARB suggests that you present your machine to the nearest authorized Timberjack dealer as soon as a problem is suspected. The warranty repairs should be completed by the service dealer as expeditiously as possible.

If you have any questions regarding your warranty rights and responsibilities, you should contact Timberjack at 1-519-537-6271, or the State of California Air Resources Board, Mobile Source Operation Division, PO Box 8001, El Monte, CA 91731-2900

The warranty period begins on the date the machine is delivered to an ultimate purchaser, or when otherwise put into service. Timberjack warrants to the ultimate purchaser and each subsequent purchaser that the engine is designed, built and equipped so as to conform with all applicable regulations adopted by the Air Resources Board, and that it is free from defects in materials and workmanship which would cause the failure of a warranted part.

Any warranted part which is scheduled for replacement as required maintenance by the operator's manual is warranted by Timberjack for the period of time prior to the first scheduled replacement point for that part. If the part fails prior to the first scheduled replacement point, the part shall be repaired or replaced under warranty. Any such part repaired or replaced under warranty is warranted for the remainder of the period prior to the first scheduled replacement point for that part.

Any warranted part which is not scheduled for replacement as required maintenance, or which is scheduled only for regular inspection to the effect of repairing or replacing as necessary, is warranted for the warranty period.

Repair or replacement of a warranted part will be performed at no charge to you by an authorized Timberjack dealer. You will not be charged for diagnostic labor which leads to the determination that a warranted part is defective, if the diagnostic work is performed by a Timberjack dealer.

Timberjack is liable for damages to other engine components caused by failure under warranty of any warranted part.

Timberjack is NOT liable for travel or mileage on extended emissions warranty service calls.

Any replacement part may be used in the performance of any maintenance or repairs, and such use will not reduce the warranty obligations of Timberjack. However, the use of add-on or modified parts are grounds for disallowing a warranty claim.

This Page Intentionally Left Blank

2. Safety Rules



LOG LOADER SAFETY FEATURES

Please remember, the operator is the key to preventing accidents.

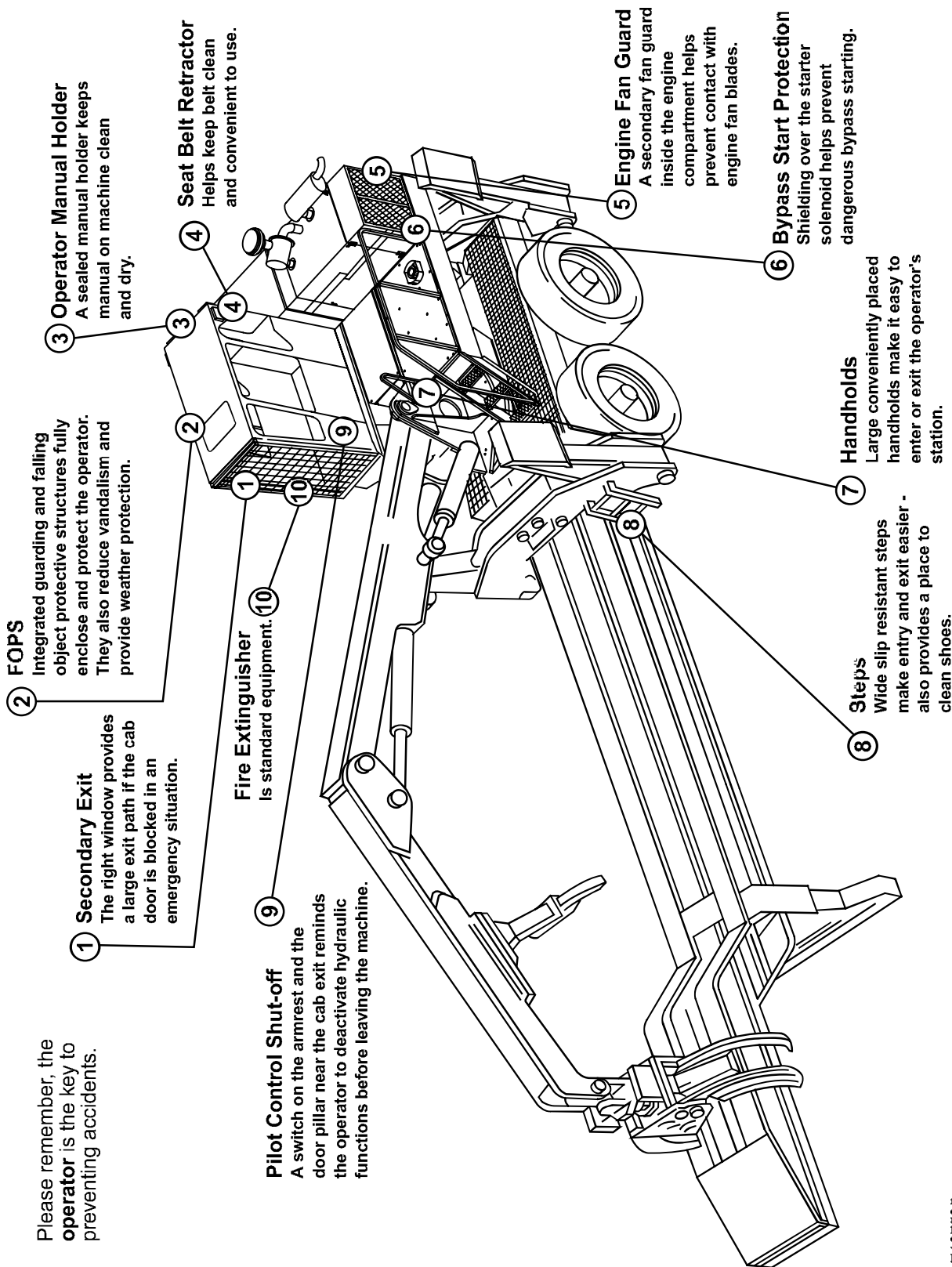

2 FOPS

Integrated guarding and falling object protective structures fully enclose and protect the operator. They also reduce vandalism and provide weather protection.

1 Secondary Exit

The right window provides a large exit path if the cab door is blocked in an emergency situation.

3 Operator Manual Holder

A sealed manual holder keeps manual on machine clean and dry.

4 Seat Belt Retractor

Helps keep belt clean and convenient to use.

10 Fire Extinguisher

is standard equipment.

9 Pilot Control Shut-off

A switch on the armrest and the door pillar near the cab exit reminds the operator to deactivate hydraulic functions before leaving the machine.

5 Engine Fan Guard

A secondary fan guard inside the engine compartment helps prevent contact with engine fan blades.

6 Bypass Start Protection

Shielding over the starter solenoid helps prevent dangerous bypass starting.

7 Handholds

Large conveniently placed handholds make it easy to enter or exit the operator's station.

8 Steps

Wide slip resistant steps make entry and exit easier - also provides a place to clean shoes.

T137595

Use Allied Equipment Information

IMPORTANT! Refer to appropriate allied equipment manual for safety information specific to your attachments.

Recognize Safety Information

This is a safety-alert symbol. When you see this symbol on your machine or in this manual, be alert to the potential for personal injury.

Follow recommended precautions and safe operating practices.



Understand Signal Words

A signal word—DANGER, WARNING, or CAUTION—is used with the safety-alert symbol. DANGER identifies the most serious hazards.

DANGER or WARNING safety signs are located near specific hazards. General precautions are listed on CAUTION safety signs. CAUTION also calls attention to safety messages in this manual.

 **DANGER**

 **WARNING**

 **CAUTION**

Follow Safety Instructions

Carefully read all safety messages in this manual and on our machine safety signs. Keep safety signs in good condition. Replace missing or damaged safety signs. Be sure new equipment components and repair parts include the current safety signs. Replacement safety signs are available from your John Deere dealer.

Learn how to operate the machine and how to use controls properly. Do not let anyone operate without instruction.

Keep your machine in proper working condition. Unauthorized modifications to the machine may impair the function and/or safety and affect machine life.

If you do not understand any part of this manual and need assistance, contact your John Deere dealer.

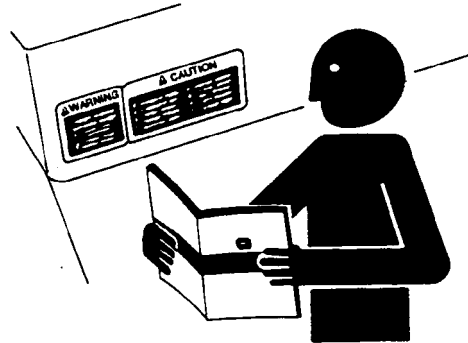

Avoid Injury From Rollover Accidents

Wear Your Seat Belt

Do Not Attempt to Jump Clear of Tipping Machine—Serious or Fatal Crushing Injuries Will Result

Machine Will Tip Over Faster Than You Can Jump Free

To avoid rollovers:

- Be careful when operating on a slope.
- Avoid sharp turns.
- Balance loads so weight is evenly distributed and load is stable.
- Carry tools and loads close to the ground to aid visibility and lower center of gravity.
- Reduce speed before turning or swinging load.
- Know capacity of machine. Do not overload.
- Be careful when operating at the edge of an excavation, trench, or drop-off, and loading or unloading from a trailer.
- Read and understand the operating instructions in the operator's manual.

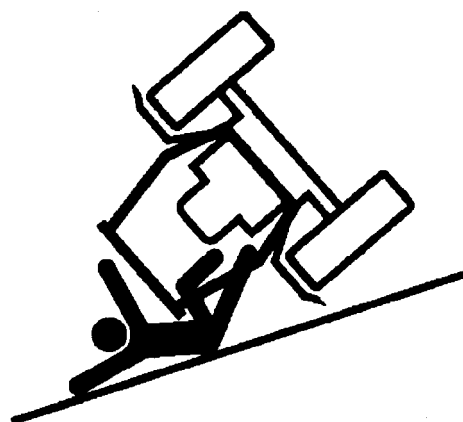

**USE
SEAT
BELT**

Avoid Injury From Backover Accidents

Before Moving Machine, Be Sure All Persons Are Clear of Area

Always Be Alert for Bystanders Moving into the Work Area. Use Horn or Other Signal to Warn Bystanders Before Moving Machine

When Using a Signal Person, Keep Person in View at All Times. Be Sure Signal Person Is Clear Before Backing Up

To avoid backover accidents:

- Always look around before you back up. Be sure that everyone is in the clear.
- Keep bystanders away from pivot area of an articulated machine.
- Keep reverse warning alarm in working condition, if equipped.
- Use a signal person when backing up if view is obstructed. Always keep signal person in view.
- Learn the meaning of all flags, signs, and markings used on the job, and who has the responsibility for signaling.
- Keep windows, mirrors, and lights clean and in good condition.
- Dust, heavy rain, fog, etc., can reduce visibility. As visibility decreases, reduce speed and use proper lighting.
- Read and understand the operating instructions in the operator's manual.

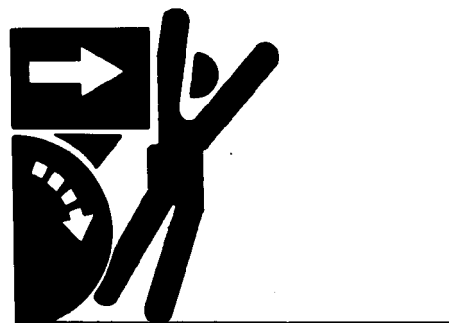

Avoid Injury From Rollaway Accidents

To Prevent Rollaway, Always Make Sure Machine Is Properly Secured Before Leaving Operator's Seat

Death or Serious Injury May Result If You Attempt to Mount or Stop a Moving Machine

To avoid rollaways:

- Select level ground when possible to park machine.
- Engage park brake.
- Lower all equipment to ground.
- Stop the engine.
- Block all wheels if you must park on a grade. Position machine to prevent rolling.
- Park a reasonable distance from other machines.
- Read and understand the operating instructions in this operator's manual.

Inspect Machine

Inspect your machine carefully each day by walking around it before you start it. (See Pre-Start Inspection chapter in operator's manual.)

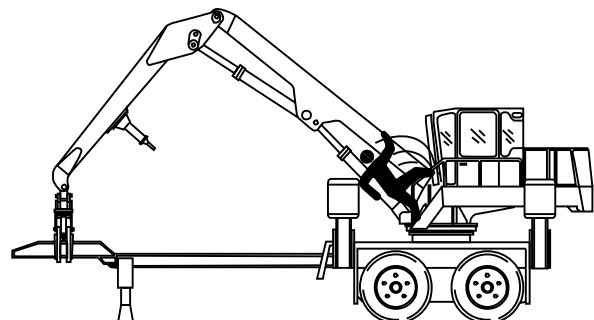

T133695



Use Handholds and Steps

Falling is one of the major causes of personal injury.

When you get on and off the machine, always maintain a three point contact with the steps and handrails, and face the machine. Do not use the steering wheel or any controls as handholds.

Never jump on or off the machine. Never mount or dismount a moving machine.

Be careful of slippery conditions on platforms, steps, and handrails when leaving the machine.



Prevent Machine Runaway

Avoid possible injury or death from machine runaway.

Do not start engine by shorting across starter terminals.

Do not leave operator's station while engine is running.

NEVER start engine while standing on ground. Start engine only from operator's seat.

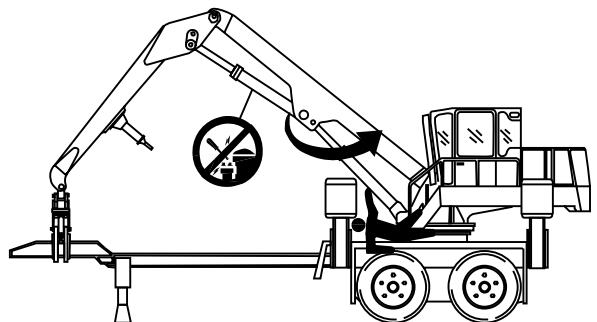

T133693

Use Seat Belt Properly

Use a seat belt when you operate with a roll-over protective structure (ROPS) or cab to minimize chance of injury from an accident such as an overturn.

Do not use a seat belt if operating without a ROPS or cab.

Replace entire seat belt if mounting hardware, buckle, belt, or retractor show signs of damage.

Inspect seat belt and mounting hardware at least once a year. Look for signs of loose hardware or belt damage, such as cuts, fraying, extreme or unusual wear, discoloration, or abrasion. Replace only with replacement parts approved for your machine. See your John Deere dealer.

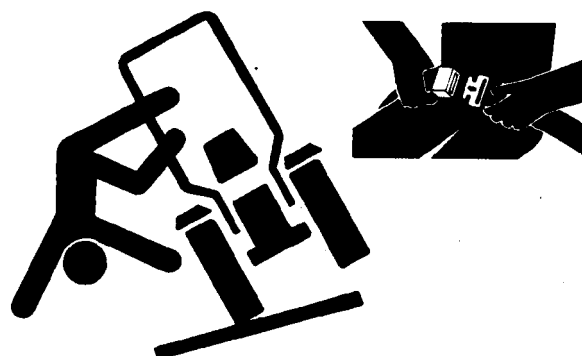

Maintain Seat Belt

It is important to use the seat belt on ROPS equipped machines to minimize the chance of injury from an accident such as an overturn. Keep the seat belt in good condition.

The complete seat belt assembly should be replaced after three years of usage, regardless of appearance.

Between replacement intervals:

- Carefully examine buckle, webbing, and attaching hardware.
- Be sure that the retractor, if equipped, locks to prevent belt extension after latching buckle.
- Be sure that attaching hardware is in place. Tighten, if necessary.
- Replace the seat belt if it does not operate properly, or if it is damaged, worn, or deteriorated.

Travel Safely

Know the location of bystanders before moving the machine.

Always keep the reverse warning alarm, if equipped, in working condition. It warns people when the machine starts to move in reverse.

Use a signal person when moving the machine in congested areas. Coordinate hand signals before starting the machine.

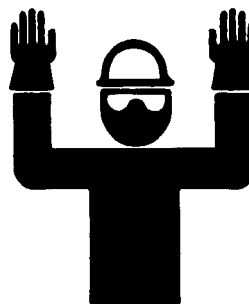

Secondary Exits

The cab right side window functions as a secondary exit. In an emergency situation rotate both latches and swing open window to exit cab.

Operate Machine Safely

Always operate the machine with the operator protective structure (OPS) in place (doors, screens, windows, windshield, etc.).

Always walk around the machine before starting and moving it. Keep bystanders clear of machine, especially before moving boom, or traveling. Always be alert for bystanders in or near the work area.

Use the seat belt under almost all operating conditions.

Never operate the machine without a functional park brake.

Avoid contact between boom and overhead obstacles when you operate, move, or haul machine.

Make sure work site footing is strong enough to firmly support the machine.

Always keep machine in gear when going down steep hills or grades. Do not coast.

If engine stops during operation on a hillside, start engine immediately and resume normal operation.